

ZB-K Series Polymer melt pump for reaction kettle

Introduction of Polymer melt pump

Polymer melt pump is mainly used for transporting medium or high viscosity medium out of the vacuum reaction kettle. On basis of large suction inlet flange design, the high viscosity medium is able to absorb inside under vacuum conditions. This series of polymer gear pump is primarily applicable for ABS, PS, PET, PC, SAN, PP, PE Biopolymers etc.



Technical Parameter of Polymer gear pump

- ◆ Melt Pump Body: stainless steel, carbon steel, hastelloy, monel
- ◆ Gear: tool steel, nitrided steel, special material and wear-resistant coating
- ◆ Tooth profile: Straight tooth, Helical tooth, Herringbone tooth
- ◆ Sliding Bearing: tool steel, Ti-Ta alloy, silver-nickel, special material and wear-resistant coating
- ◆ Shaft Sealing: mechanical seal, Screw sealing+Packing seal, flushing fluid combined sealing
- ◆ Heating System: Electrical heating

Operating Parameter of Polymer pump

- ◆ Theory: Positive Displacement Gear Pump
- ◆ Structure: Gear Pump
- ◆ Usage: Plastic, Rubber Pump and Fiber
- ◆ Power: Electric or Oil
- ◆ Fuel: No Need
- ◆ Volume Range: 0.5CC - 12000CC
- ◆ Viscosity: ≤ 40000 Pas
- ◆ Working Temperature: $\leq 400^{\circ}$ C(750° F)
- ◆ Cleaning Temperature: $\leq 450^{\circ}$ C(850° F)
- ◆ Inlet Pressure: Vacuum--1.5MPa
- ◆ Outlet Pressure: 40Mpa

Features of Polymer gear pump

- ◆ Stabilizing outlet pressure;
- ◆ Improving the products quality;

Main Product: [melt pumps](#), gear pumps, metering pump; [loss-in-weight feeders](#), weight feeder, liquid feeder, gravimetric feeder, volumetric feeders; [screen changer](#), polymer filter, melt filtration equipment.

- ◆ Increasing the extrusion output;
- ◆ Reducing unit energy consumption;
- ◆ Prolonging the service time of extruder.

Application of High viscosity pump

- ◆ Polymer extrusion molding, such as granulation, film, pipe, plate, sheet, etc;
- ◆ High-viscosity materials:ABS, PS, PET, PC, SAN, PP, PE Biopolymers etc;
- ◆ Rubber, asphalt, paint, adhesives, coatings, lubricants, polyalcohol, non-particulate impurities;
- ◆ Polyester for cotton-fiber, polypropylene and other chemical fiber melt.

Structure of High viscosity gear pump

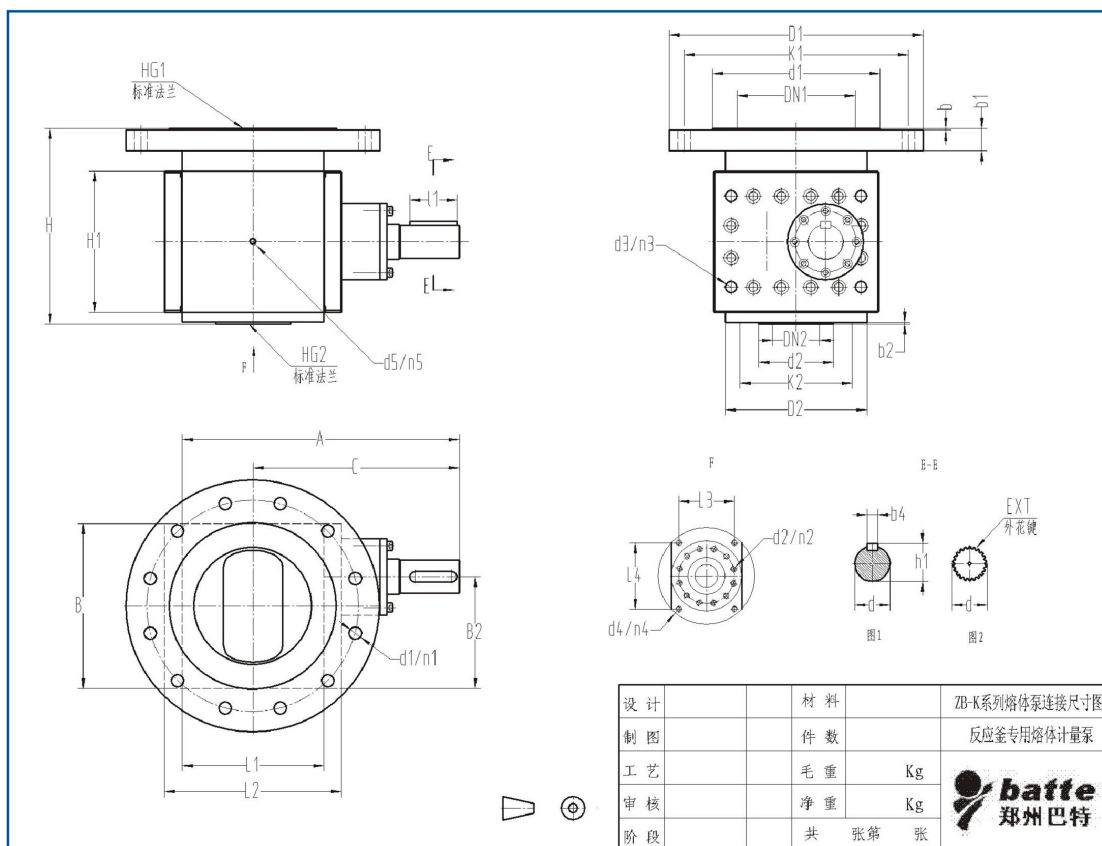

Parameters of High viscosity gear pumps

Type	CC/Rev	Capacity (L/H)	Heating power (kw)	Dirven system (kw)	Pressure	Temperature
ZB-0.2	0.2	0.2-0.6	0.5	0.37		
ZB-1	1	1-3	1	0.5		
ZB-2	2	2-6	1	0.75		
ZB-5	5	5-15	1	1.1		
ZB-10	10	10-30	1	1.5		

ZB-20	20	20-60	2	2.2	Inlet pressure: ≥ 0 Mpa Exit pressure: ≤ 35 Mpa	Operating temperature: $\leq 350^{\circ}\text{C}$ Clearing temperature: $\leq 450^{\circ}\text{C}$
ZB-31.5	31.5	30-90	2	3		
ZB-50	50	50-150	2	4		
ZB-100	100	100-300	3	5.5		
ZB-150	150	150-450	4	7.5		
ZB-200	200	200-600	4	11		
ZB-250	250	250-750	5	15		
ZB-315	315	300-900	6	18.5		
ZB-400	400	400-1200	8	22		
ZB-500	500	500-1500	10	30		
ZB-630	630	600-1800	12	37		
ZB-800	800	800-2400	15	45		
ZB-1000	1000	1000-3000	18	55		
ZB-1500	1500	1200-4500	20	75		

The other Products



- [ZB-B Gear melt pump](#)
- [ZB-C Extruder melt pump](#)
- [ZB-D Extruding pump for polymer](#)
- [ZB-E Pressurized melt pump](#)
- [ZB-F Melt pump for reaction kettle](#)
- [ZB-H High temperature and high pressure melt pump](#)
- [ZB-K Polymer melt pump](#)
- [ZB-R Gear pump for rubber extruder](#)
- [ZB-U Spinning gear metering pump](#)
- [ZB-X Chemical transporting and dosing pump](#)

Skype: [Battemachinery](https://www.skype.com/BatteMachinery)

info@battemachinery.com
sale@meltump.com

- [Double plate hydraulic screen changer](#)
- [Manual control screen changer](#)
- [Double piston four screen cavities screen changer](#)
- [Automatic mesh belt continuous screen changer](#)
- [Single piston screen changer](#)
- [Single plate screen changer](#)
- [Double piston double screen cavities screen changer](#)
- [Four screen cavities backflash screen changer](#)

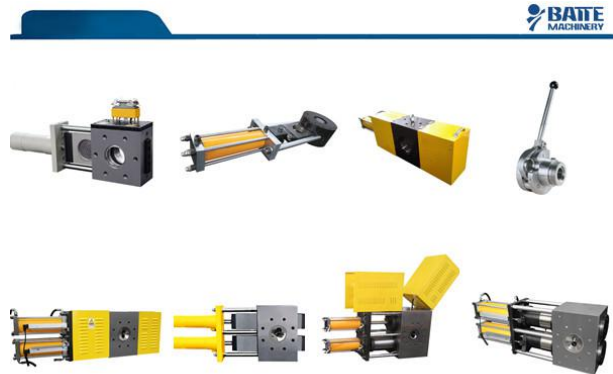

Skype: Battemachinery

info@battemachinery.com
sale@meltump.com



Skype: Battemachinery

info@battemachinery.com
sale@meltump.com

- [Single screw gravimetric dosing feeder](#)
- [Single screw gravimetric feeder](#)
- [Twin screw loss in weight metering feeder](#)
- [Twin screw loss in weight feeder](#)
- [Volume feeding machine \(single screw,twin screw\)](#)
- [Micro loss in weight metering feeder](#)
- [Micro loss in weight feeder](#)
- [Liquid loss in weight feeder](#)
- [Multi-component loss in weight feeder](#)